

BBQ MODULE WITH INTEGRATED AIR FRAME

(SIZES: 800mm - 1165mm)



ASSEMBLY INSTRUCTIONS

WARNING! – THIS IS A PERMANENT CONNECTION SYSTEM!

WHAT'S NEEDED?

Tools Required:

- Nylon mallet (not included)
- Philips head screwdriver with long shaft or battery drill with long bits (not included)
- Allen keys x 2 (included)
- 50mm diameter Hole Saw or Jigsaw (not included)

THIS MODULE IS PACKED INTO TWO BOXES

Box 1 of 2 – BBQ MODULE PANELS AND FRAMES

- PVC & Thermal Panels and Frames
- Hardware Blister Pack
- Plinth Feet

Box 2 of 2 – DOORS

Essential Tip: Ensure you have a stable, flat surface to knock your modules together on; ideally concrete.

Please take the time to look at our instruction manual, to familiarise yourself with the product, before starting.

Before any work/modification is done on/to this product please refer to the link to the SDS for your personal protection requirements.

Web: <https://sitro.com.au/support/sds/>

Call: 1300 174 876

LAYOUT DIAGRAM

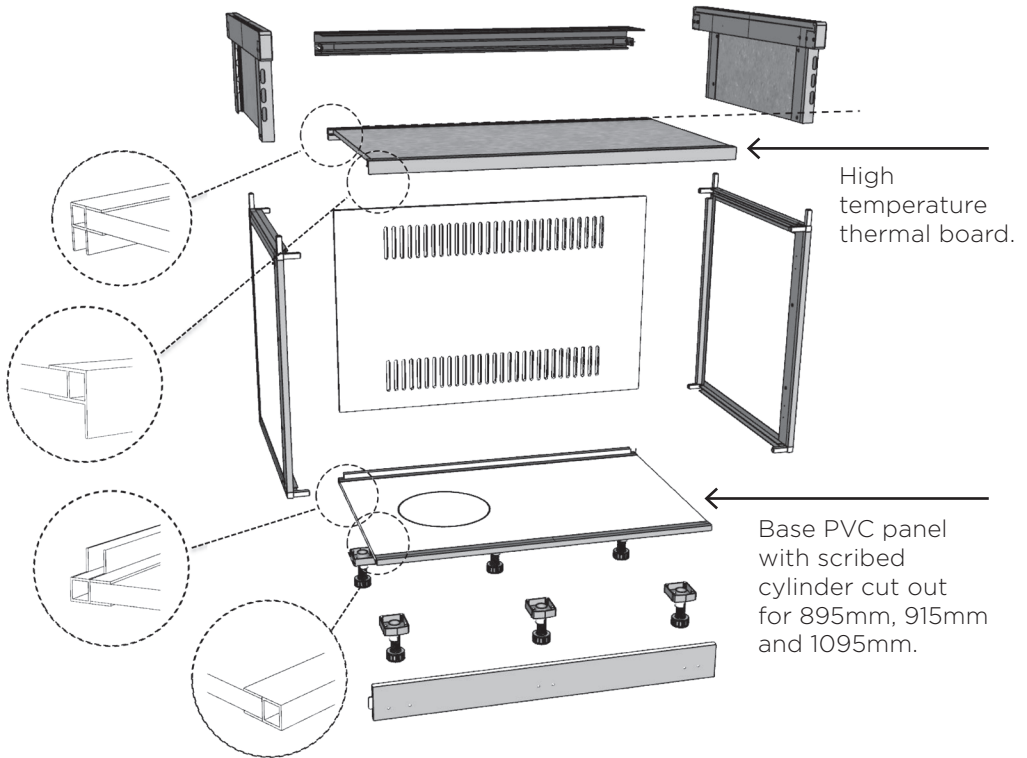

FIG. 1

Cylinder Hole Indicator Line: Check your BBQ's gas inlet position, some BBQ's gas inlets are located on the left and other BBQ models are located on the right hand side. If your BBQ's gas inlet is located on the right hand side you can easily swap the PVC board around by removing the frames and re attaching the frames in the reversed position.

If your gas bottle height exceeds that of the cabinet you may cut a hole through the PVC board as indicated, whereby your gas bottle will fit inside the locating hole. Various holes will have to be cut or drilled with a hole saw where required for gas, power, water and waste.

Essential Tip: Ensure you have a stable flat surface or workbench to work from. We recommend cardboard or carpet piece on a concrete floor.

BBQ MODULE ASSEMBLY

Note: Assemble the module on its side.

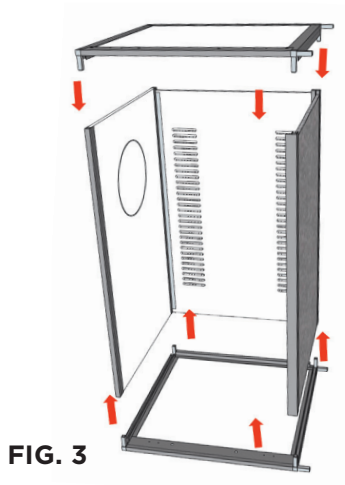
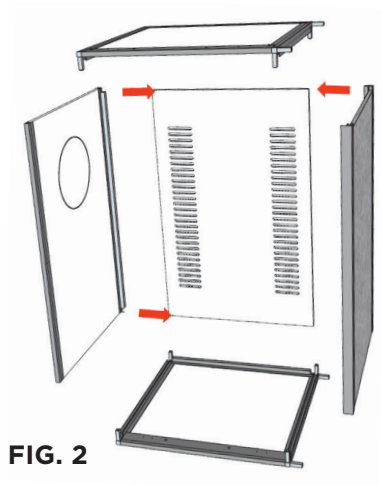

Note: Now turn the module 90 degrees back onto its base.

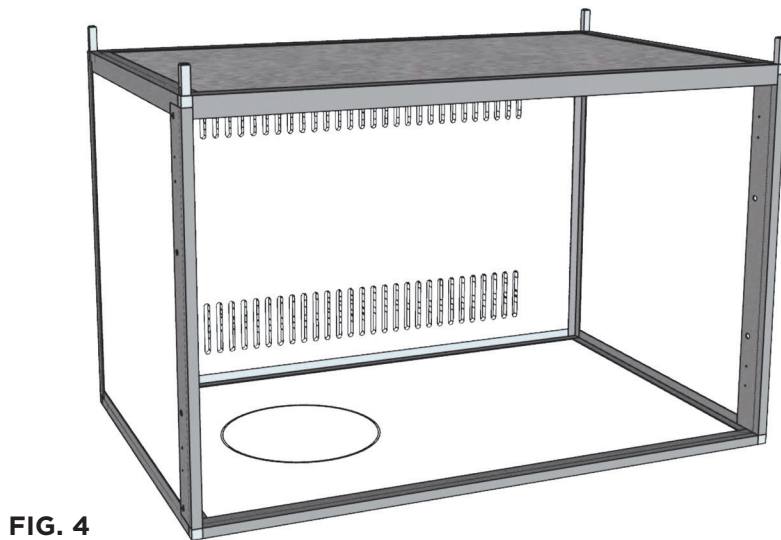

ASSEMBLING PLINTH FEET & KICK PLATE

There are no pilot holes provided for fitting the plinth feet, use the inside of the frame edge as a guide.

Place plinth foot into corner of cabinet frame. Secure with screws provided. If easier, remove plinth shaft from baseplate, then screw down base plate first. If desired, move the front two plinth feet further back to create a deeper kick-plate position.

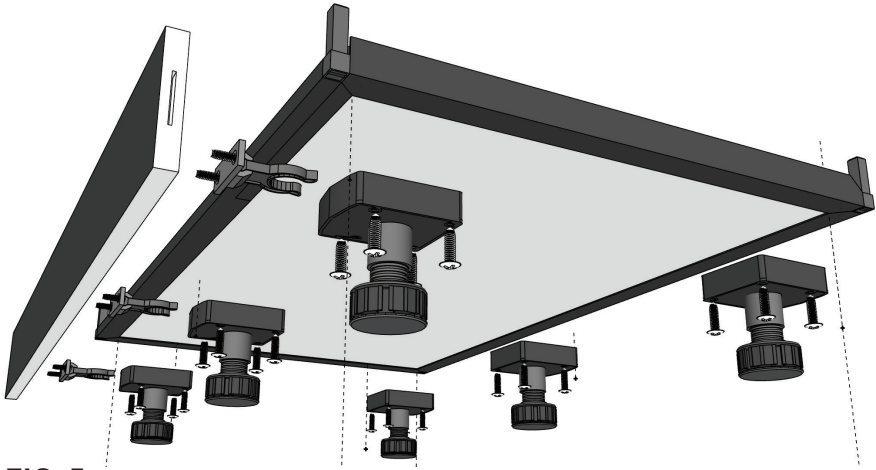

FIG. 5

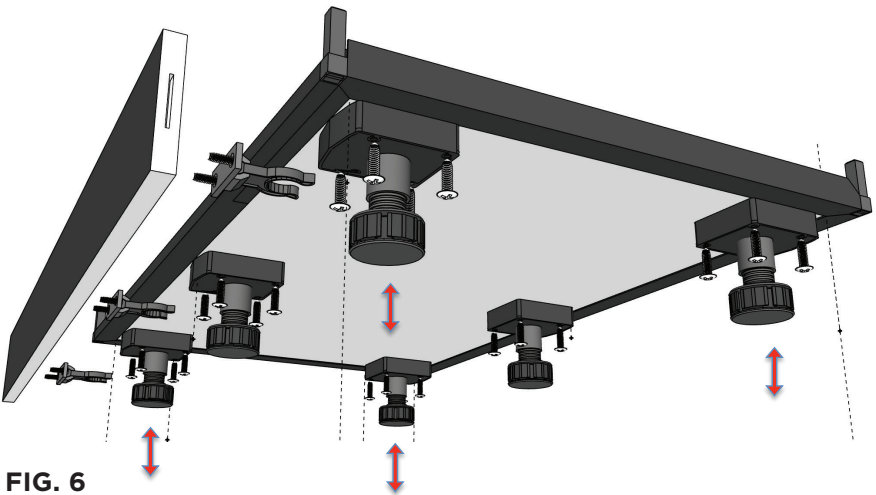
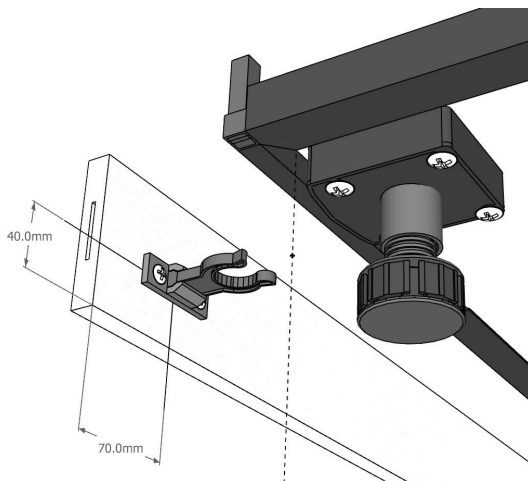
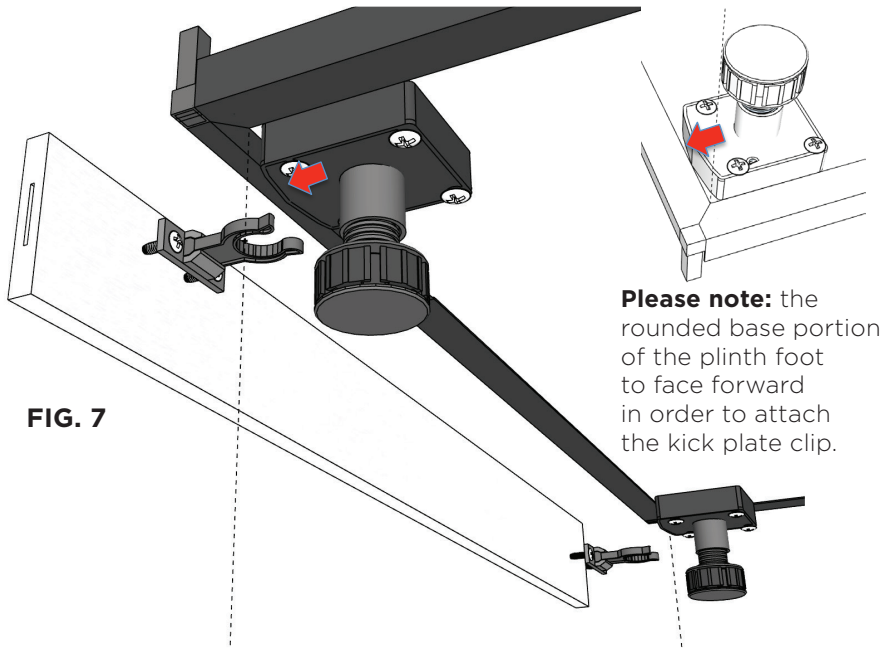

FIG. 6

ATTACHING THE KICK PLATE

Please take note that the kick plate provided is reversible, giving you the choice between a black finish or stylish silver finish. The kick plate biscuit is used to connect and align adjoining kick plate.



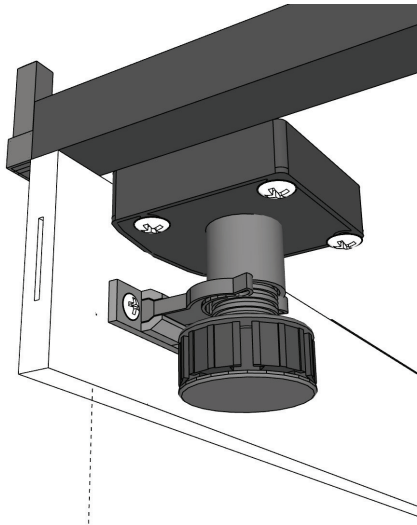

FIG. 9

Choose the desired colour face of kick plate (silver or black).

No pre-drilled holes are possible due to this color option. Self tapping screws are provided to attach the spring clip base to the kick panel.

The dimensions on FIG. 8 can be used as a guide only since the position of the plinth foot and the desired depth of the kick plate will vary depending on the plinth foot installation position by the end user.

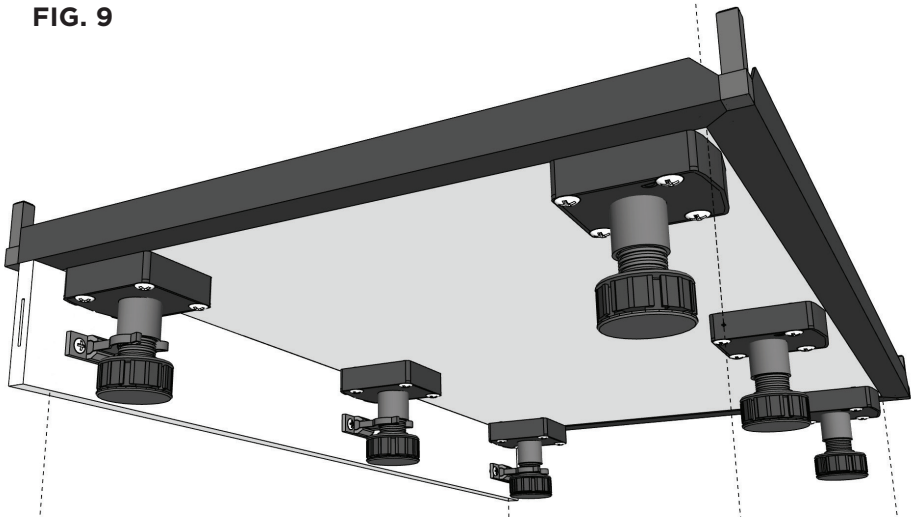

FIG. 10

ASSEMBLING DOOR & HINGES

- To attach the hinge plate use a standard or power Phillips head screw driver. The holes are pre-drilled into the frame.
- Attach all four-hinge plates when attaching two doors.

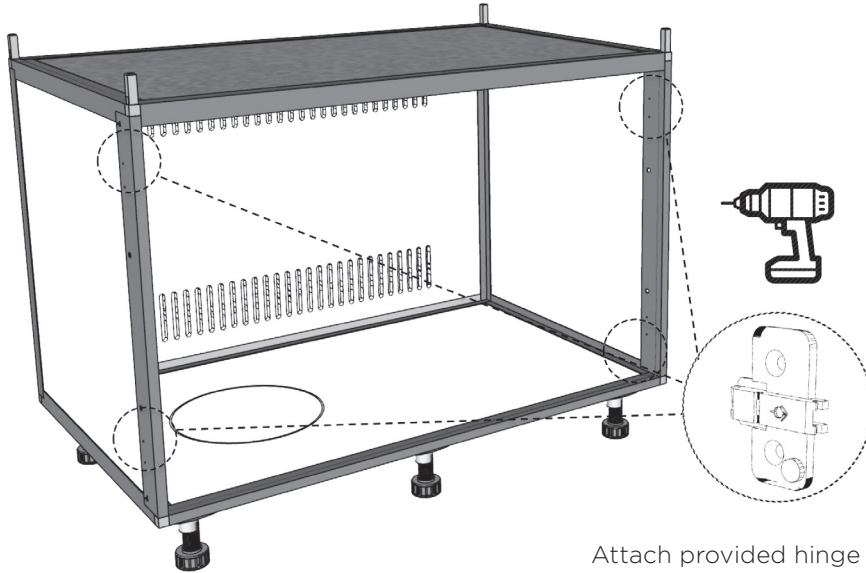
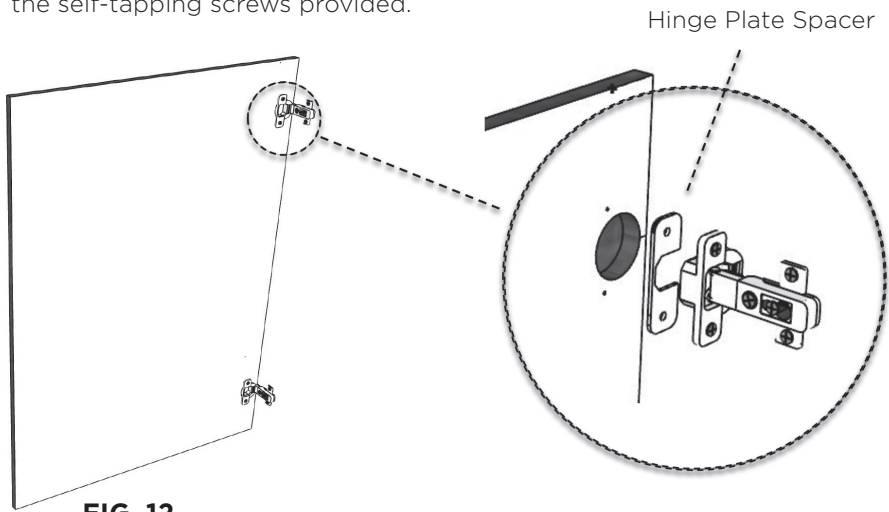

FIG. 11

Attach provided hinge plate x 4 and self tapping screws.

Attach hinges to door panels by using the self-tapping screws provided.



DETAILED INSTRUCTIONS ON HOW TO CLIP ON THE DOORS USING CLIP-ON-HINGES

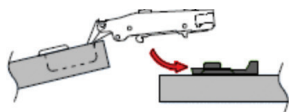

Clip On Hinge Instructions:

Clamp hinge on to the mounting plate as shown by direction arrow

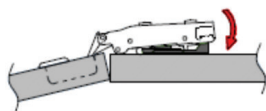

Press down the hinge arm to lock the plate as shown

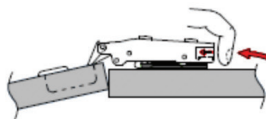

The door can be quickly removed by pushing the button

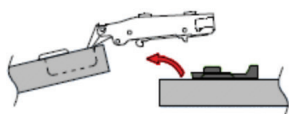

Unclipping the door from the mounting plate leaves all adjustments unaltered

Firstly align the front hinge section with the front section of the hinge-plate, then press on the back of the hinge-plate, an audible “click” should be heard if the door has been correctly hanged. Repeat the process to secure the bottom hinge and door.



FIG. 13

The door should fully open and close as normal.



FIG. 14

At this stage your progress should look like the above image.

ATTACHING & LEVELLING THE MODULES

Position modules in the desired configurations. Level each module and ensure the heights are correct so that joining holes line up. Now join the two modules with the barrel bolts supplied.

Do not over tighten barrel bolts. Position and level the whole assembly when in final position.

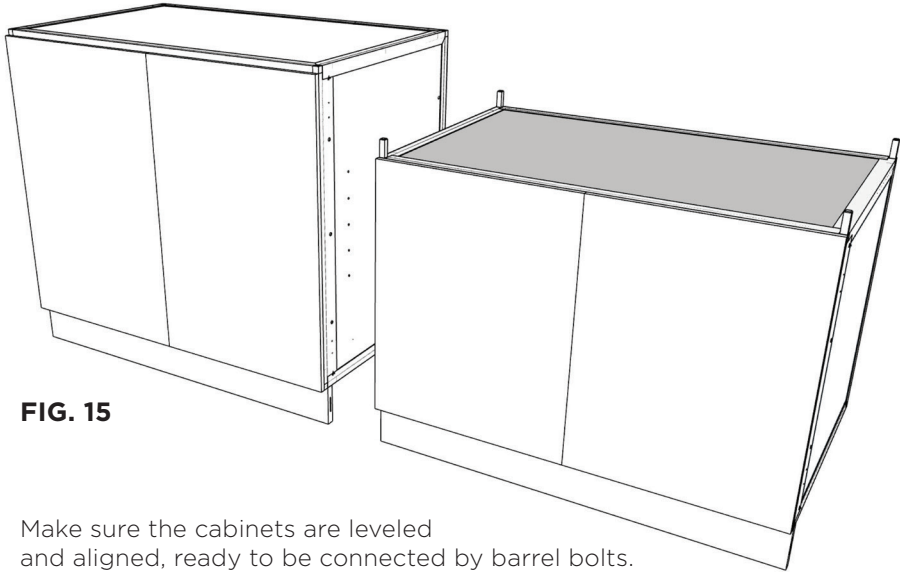

FIG. 15

Make sure the cabinets are leveled and aligned, ready to be connected by barrel bolts.

Please note: insert the biscuit into the slot in the kick plate, then align the kick plate ready to be connected.

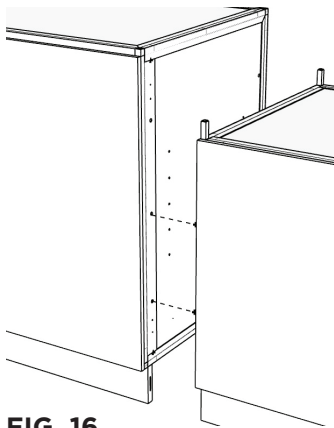

FIG. 16

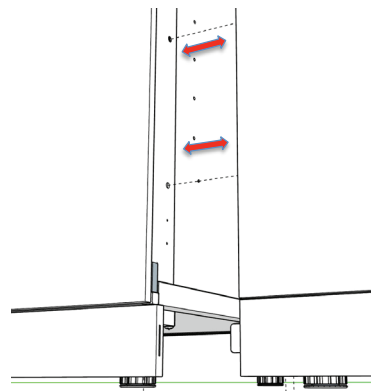

FIG. 17

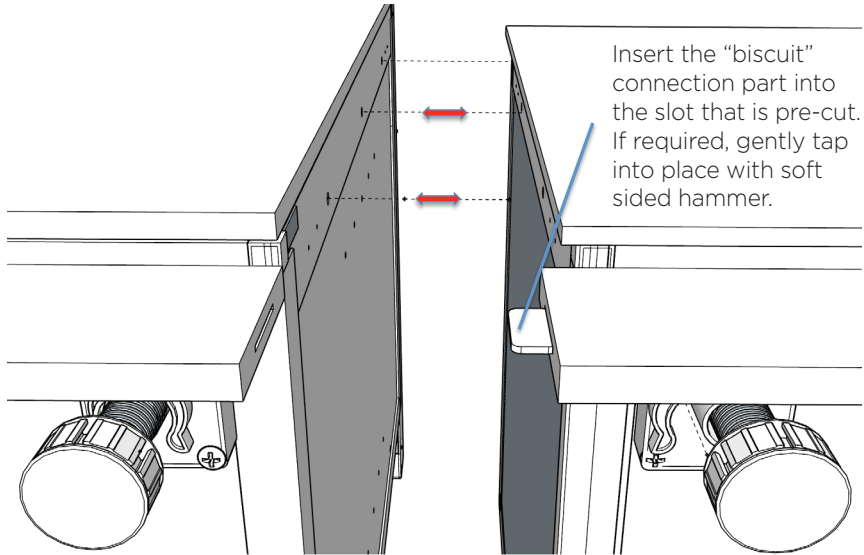

FIG. 18

Diagram using the Allen key provided to fasten cabinets using the barrel bolts.

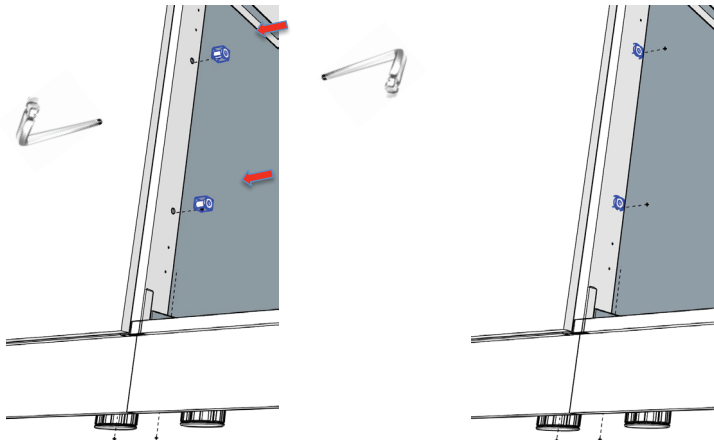

FIG. 19

Joining the cabinet with barrel bolts.

Cabinet joined with barrel bolts.

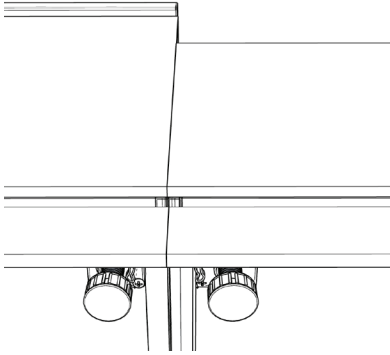

FIG. 20

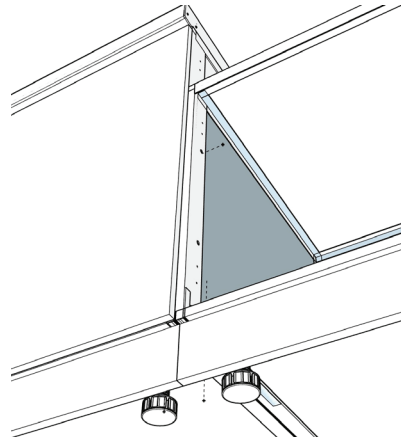

FIG. 21

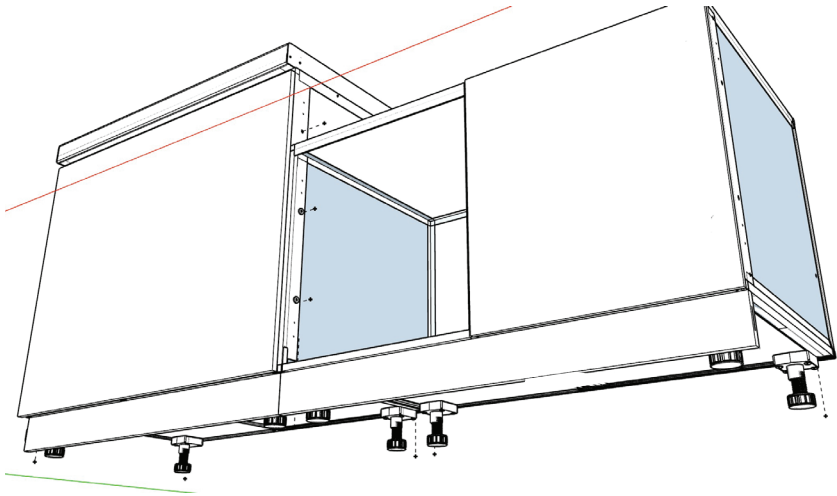
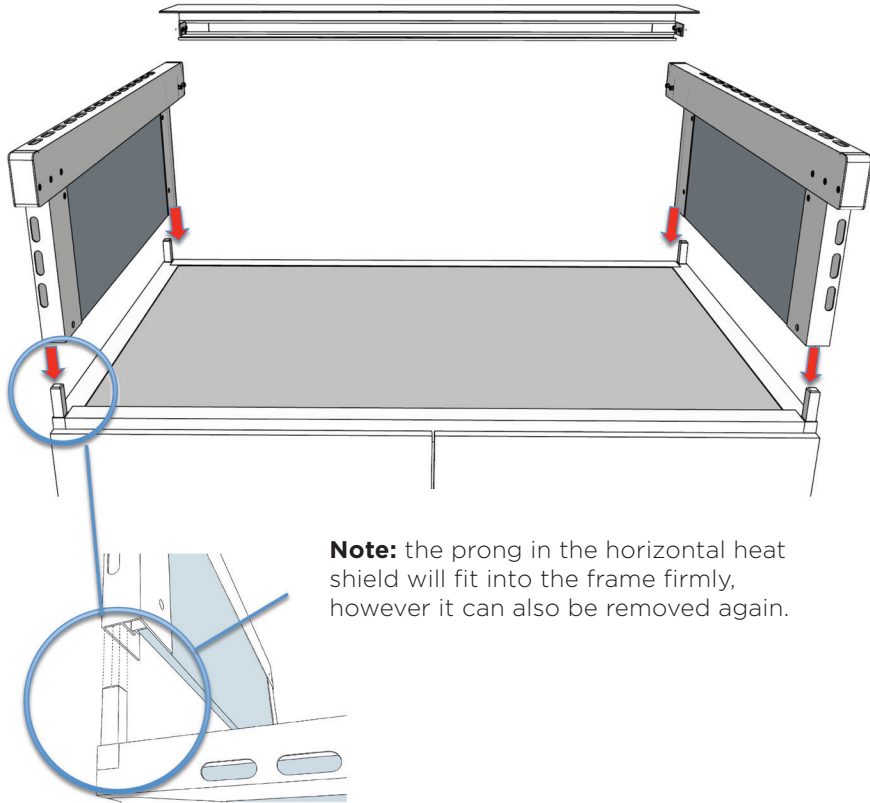

FIG. 22

Note: the door is not shown in some images to illustrate the cabinet connection method more clearly.

ASSEMBLING THE AIR FRAME

Insert the pre-assembled vertical side shields onto the horizontal bottom heat shields by pressing firmly into pre inserted prongs. The infill panel should still remain loose at this point.



Note: the prong in the horizontal heat shield will fit into the frame firmly, however it can also be removed again.

FIG. 23

After the heat shield left and right hand side have been assembled your Air Frame should resemble the diagram below.

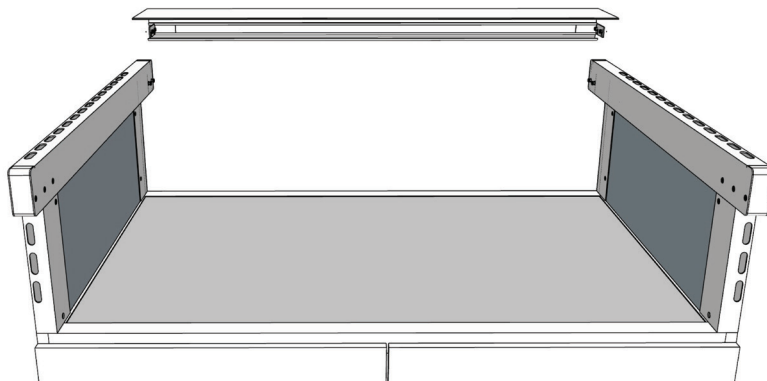

FIG. 24

The Air Frame will be firmly attached along with the BBQ module by making use of the barrel bolts provided to join to the cabinets or end panels directly adjacent to the Air Frame.

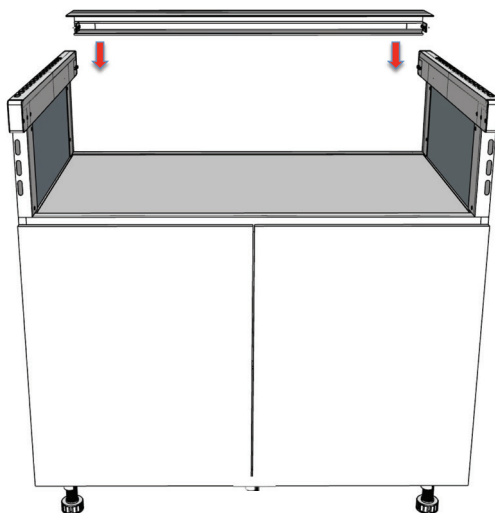

FIG. 25

Attach the joining screw bolt through the pre-drilled holes provided. Make use of the Allen keys. Do not over tighten.

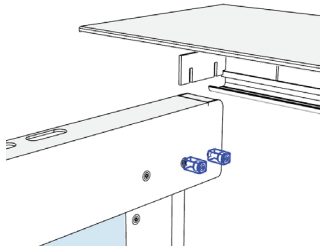

FIG. 26

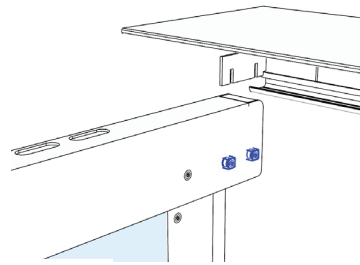

FIG. 27

Step 1: Insert shoulder screws roughly halfway.

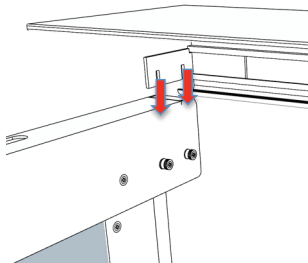

FIG. 28

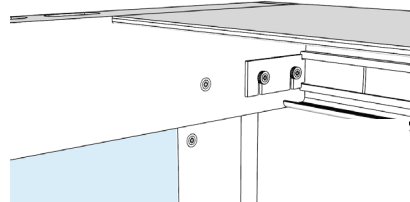

FIG. 29

Step 2: Lower Infill panel onto shoulder screws and tighten. Do not over tighten.

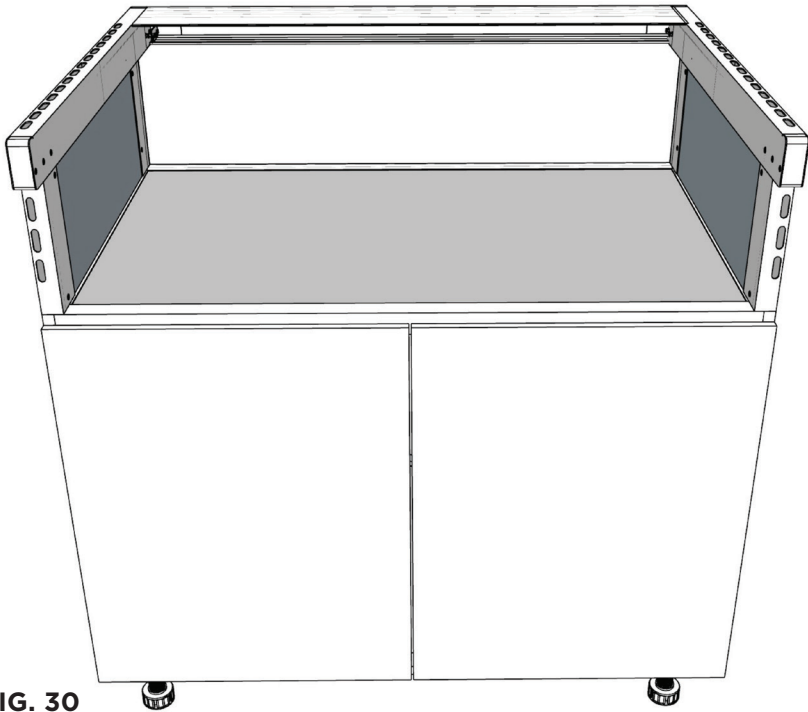

FIG. 30

HOW TO INSTALL A DOOR HANDLE

Take note that the door handles can be placed vertically or horizontally as preferred by you.

Remove the double sided tape from the inside of the handle. Ensure you align the edge of the handle to the edge of the door before touching the tape to the door panel.

Carefully press the door handle to the door for a permanent adhesion.

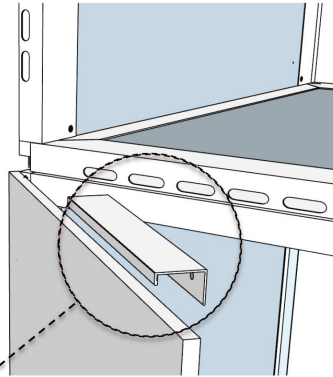

FIG. 31

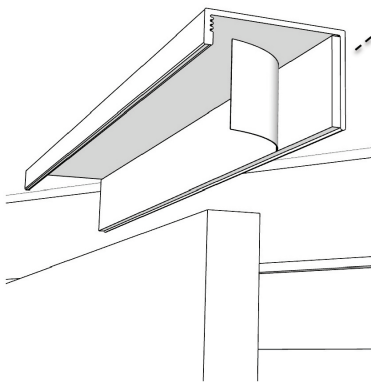

FIG. 32

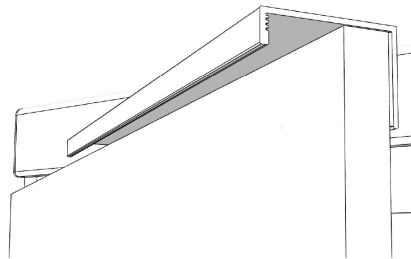

FIG. 33

Additional screws are provided for a very secure connection, although you need to drill your own holes due to the handle having multiple possible positions as desired. These additional screw fixtures are not required under normal use.

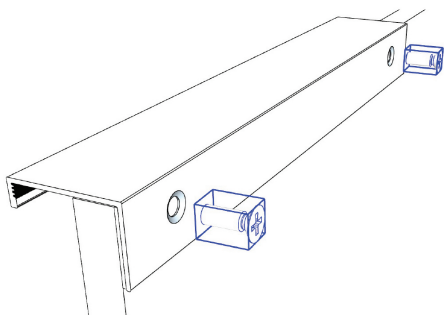

FIG. 34

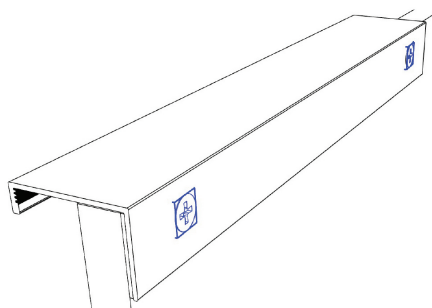

FIG. 35

IMPORTANT

- **3.2mm drill bit with a depth stop (not supplied).**

Please ensure you use a stop or tape on the drill bit, so not to drill deeper than 9mm maximum into the door. Damage to the door from incorrect drilling will not be covered under warranty.

Use tape to set the depth to 9mm max.

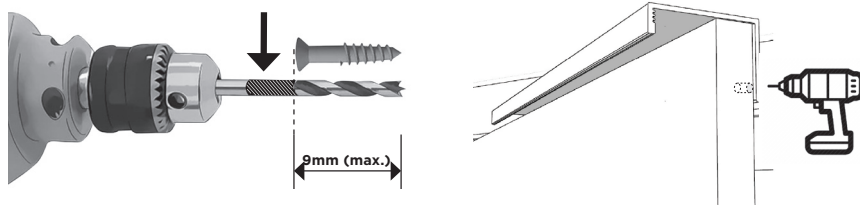

FIG. 36

For any queries or assistance call:

Customer Service
Australia Only

1300 174 876
service.group@sitro.com.au

Hours of operation:
Monday to Friday 8am - 5pm

Do not return to place of purchase
Keep your purchase receipt, this will be required
to make any claims under the warranty.